

HOLEMAKER PRO 110 LARGE CAPACITY #4 MORSE TAPER HEAVY DUTY MACHINE



The Holemaker PRO 110 is an extra heavy duty, large capacity machine capable of producing burr-free holes up to 110mm diameter by 110mm depth. 1650w motor with 4-speed mechanical gearbox produces superb torque through gear reduction in low speeds. No. 4 Morse Taper spindle bore for use with taper shank drills, tapping head (M30 Capacity) and taper shank reamers.



Supplied complete with side mounted coolant system and arbor for use with 3/4" shank Holemaker cutters up to 75mm diameter and 75mm depth of cut. Optional arbor to take 1-1/4" shank cutters up to 110mm diameter and 110mm depth. 1100ml pressure feed coolant bottle available, recommended for use with large diameter and depth hole drilling.

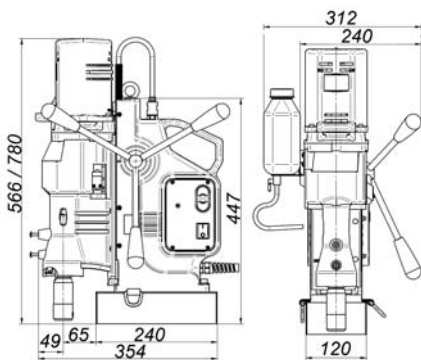

OPTIONAL ACCESSORIES & CONSUMABLES



Holemaker Cutters - pg24



Taper Shank Drills



Twist Drill Chuck - pg17



M7 Spring Balancer -pg248

Large Holes WITH THE HOLEMAKER PRO 110

Holemaker annular cutters are available up to 75mm diameter with a standard 3/4" Weldon shank.

61mm to 150mm diameter cutters are available with a 1-1/4" shank, to help increase the strength of the cutter.

The Holemaker Pro 110 is supplied as standard with No. 4 Morse Taper arbor for use with 3/4" shank Holemaker cutters up to 75mm diameter and 75mm depth of cut.

Alternatively the Pro 110 can be ordered with a number of different No. 4 Morse Taper arbors, depending on your specific job requirements.



Part No.	Morse Taper	Maximum Depth Of Cut	To Suit Shank Size
SAIA4S	#4 MT	50mm	3/4"
SAIA4S-100	#4 MT	110mm	3/4"
SAIA4SW	#4 MT	50mm	1-1/4"
SAIA4SW-100	#4 MT	110mm	1-1/4"

For example, when drilling a 82mm diameter hole through 100mm solid steel, arbor part# SAIA4SW-100 would be used with a Holemaker Maxi-Cut Cutter part# MAX100-82B (see page 41)

When drilling large diameter or deep holes with the Holemaker Pro 110, the optional 1100ml pressure feed coolant tank is highly beneficial.

The pressure feed tank will increase the coolant flow to the centre of the cut, and will also allow for larger cuts to be completed, without having to re-fill the coolant tank during the cutting process.



Part No.	Description
SA-WPB	1100ml Pressure Feed Coolant Bottle

Part No.	HMPRO110
Capacity (Diameter)	110mm
Capacity (Depth)	110mm
Capacity (Twist Drill)	#4 Morse Taper 47mm
Motor Power	1650 watt
Input Power	1800 watt Single Phase 240V
Gearbox	4 Speed Heavy Duty Mechanical Gearbox 85 / 135 / 160 / 250rpm
Weight	31.0kg
Magnetic Dead Lift	22000Nm On 25mm Steel Plate
Stroke	214mm
Height (min / max)	566mm / 780mm
Through Spindle Coolant System	
Smart Magnet Technology To Ensure Sufficient Magnetic Adhesion	
Supplied In Metal Carry Case With Cutter Guard & Safety Strap	