

HOLEMAKER PRO 40 DURABLE & VERSATILE MACHINE



The Holemaker Pro 40 is a highly versatile, durable machine, offering exceptional value for money.

This quality European machine features a 1020 watt industrial motor, powerful dual coil magnet and cutting capacity of 40mm diameter and 52mm depth using Holemaker cutters.

Offered as standard with a grub screw arbor system, which fastens positively onto Holemaker cutters. A Quick Grip Arbor System is available as an option.



The through cutter coolant feed, with an external side mounted gravity feed coolant tank ensures smooth fast clean hole cutting.

The feed handles can be placed on either the left or right hand side, for increased versatility.

An optional drill chuck system is available (SA70102), giving the ability to use twist drills up to 13mm diameter. The drill chuck system replaces the entire weldon arbor, allowing the full stroke of the machine to be utilised when using drill bits.

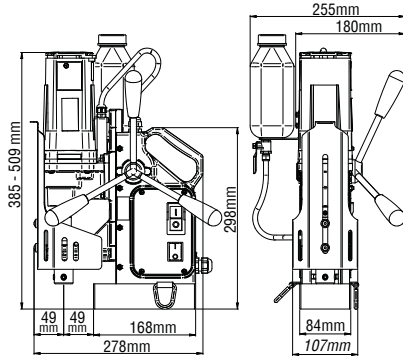

OPTIONAL ACCESSORIES & CONSUMABLES



Holemaker Cutters - pg24



Twist Drill Chuck - pg17



M7 Spring Balancer -pg248

Part No.	HMPRO40
Capacity (Diameter)	40mm
Capacity (Depth)	52mm
Capacity (Twist Drill)	13mm
Motor Power	1020 watt
Input Power	1100 watt Single Phase 240V
Speed	440rpm
Weight	12.5kg
Magnetic Dead Lift	10650Nm On 25mm Steel Plate
Stroke	124mm
Height (min / max)	385 / 509mm
Through Spindle Coolant System	
Smart Magnet Technology To Ensure Sufficient Magnetic Adhesion	
Supplied In Metal Carry Case With Cutter Guard & Safety Strap	

HOLEMAKER PRO 40 QG AS PER THE HOLEMAKER PRO 40 WITH QUICK GRIP ARBOR SYSTEM



The Holemaker PRO 40 is available with an optional Quick Grip Arbor System.

This arbor offers a fast, tool-less approach to inserting and removing Holemaker cutters.

The Quick Grip Arbor System is suitable for use with standard Weldon Shank annular cutters with 2 flat sections at 90°, as well as Holemaker universal shank cutters.



Part No.	Description
HMPRO40QG	Holemaker Pro 40 With Quick Grip Arbor

HOLEMAKER PRO 40 GR AS PER THE HOLEMAKER PRO 40 WITH FEED GEAR REDUCTION SYSTEM



The Holemaker Pro 40 is available with Feed Gear Reduction. This unique feature reduces the gearing 2:1 on the down feed which makes for smoother hole cutting and ease of operation.



This feature is highly beneficial when drilling hardened steels such as Bisalloy, wear plate and exotic alloys.

Part No.	Description
HMPRO40GR	Holemaker Pro 40 With Feed Gear Reduction

HOLEMAKER PRO 40 OPTIONAL DRILL CHUCK

An optional drill chuck system is available for the Holemaker Pro 40, as pictured, giving the ability to use twist drills up to 13mm diameter. The drill chuck system replaces the entire Weldon arbor, allowing the full stroke of the machine to be utilised when using drill bits. Suitable for use with Jobber drills up to 10.0mm. Suitable for use with Stub drills up to 13.0mm.



Part No.	Description
SA70102	13mm Drill Chuck & Adaptor To Suit PRO 40