

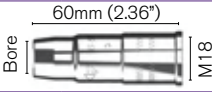

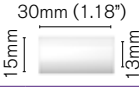

ESB CONSUMABLES

Compatible with PSF 160

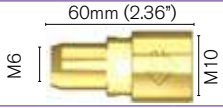

Nozzles c/w Insulators		
	STOCK CODE	BORE
	366-946-880	11mm (.43")
	366-854-880	13mm (1/2")
Nozzle Insulator		
	STOCK CODE	
	366-396-001	

Contact Tips				
	STOCK CODE	WIRE SIZE	MATERIAL	
	153-500-001	0.6mm (.023")	ECu	
	153-500-002	0.8mm (.030") CO ₂	ECu	
	153-500-003	0.8mm (.030")	ECu	
	153-500-004	0.9mm (.035")	ECu	
				
	STOCK CODE	WIRE SIZE	MATERIAL	
	468-500-001	0.6mm (.023")	CuCrZr	
	468-500-002	0.8mm (.030") CO ₂	CuCrZr	
468-500-003	0.8mm (.030")	CuCrZr		
468-500-004	0.9mm (.035")	CuCrZr		
468-500-005	1.0mm (.040")	CuCrZr		

Tip Adaptor			
	STOCK CODE	TIP THREAD	NECK THREAD
	469-249-001	M6	M10

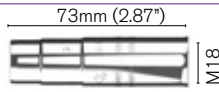
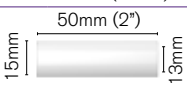

Compatible with PSF 250

Nozzles c/w Insulators		
	STOCK CODE	BORE
	366-946-881	12mm (15/32")
	366-854-881	14mm (9/16")
Nozzle Insulator		
	STOCK CODE	
	366-396-002	

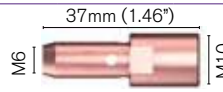
Contact Tips				
	STOCK CODE	WIRE SIZE	MATERIAL	
	153-500-001	0.6mm (.023")	ECu	
	153-500-002	0.8mm (.030") CO ₂	ECu	
	153-500-003	0.8mm (.030")	ECu	
	153-500-004	0.9mm (.035")	ECu	
				
	STOCK CODE	WIRE SIZE	MATERIAL	
	468-500-001	0.6mm (.023")	CuCrZr	
	468-500-002	0.8mm (.030") CO ₂	CuCrZr	
468-500-003	0.8mm (.030")	CuCrZr		
468-500-004	0.9mm (.035")	CuCrZr		
468-500-005	1.0mm (.040")	CuCrZr		

Tip Adaptor			
	STOCK CODE	TIP THREAD	NECK THREAD
	366-314-001	M6	M10

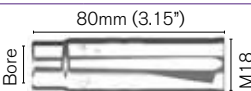
Compatible with PSF 305/315

Nozzles c/w Insulators		
	STOCK CODE	BORE
	366-946-882	13mm (1/2")
	366-854-882	16mm (5/8")
Nozzle Insulator		
	STOCK CODE	
	366-396-003	

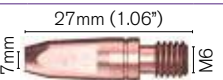
Contact Tips			
	STOCK CODE	WIRE SIZE	MATERIAL
	468-500-001	0.6mm (.023")	CuCrZr
	468-500-002	0.8mm (.030") CO ₂	CuCrZr
	468-500-003	0.8mm (.030")	CuCrZr
	468-500-004	0.9mm (.035")	CuCrZr
	468-500-005	1.0mm (.040")	CuCrZr
	468-500-007	1.2mm (.045")	CuCrZr
	468-500-008	1.4mm (.055")	CuCrZr

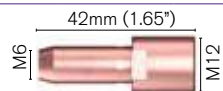
Tip Adaptor			
	STOCK CODE	TIP THREAD	NECK THREAD
	366-394-001	M6	M12

Use of the manufacturers part number and model number is for reference only. These products are not endorsed by the original manufacturer.

Compatible with PSF 400/405

Nozzles c/w Insulators		
	STOCK CODE	BORE
	366-946-883	14mm (9/16")
366-854-883	16mm (5/8")	
Nozzle Insulator		
	STOCK CODE	
	366-396-004	

Contact Tips			
	STOCK CODE	WIRE SIZE	MATERIAL
	468-502-003	0.8mm (.030")	CuCrZr
	468-502-004	0.9mm (.035")	CuCrZr
	468-502-005	1.0mm (.040")	CuCrZr
	468-502-006	1.1mm (.043")	CuCrZr
	468-502-007	1.2mm (.045")	CuCrZr
	468-502-008	1.4mm (.055")	CuCrZr
	468-502-009	1.6mm (1/16")	CuCrZr
	468-502-010	1.6mm (1/16") CO ₂	CuCrZr

Tip Adaptor			
	STOCK CODE	TIP THREAD	NECK THREAD
	366-394-002	M8	M12

LINERS

	STOCK CODE	LENGTH	WIRE SIZE	APPLICATION	PSF160	PSF250	PSF305/315	PSF400/425
Steel	366-359-882	3m	0.6-0.8mm (.023-.030")	Steel Wires	■	■	■	■
	366-549-883	4.5m	0.6-0.8mm (.023-.030")	Steel Wires	■	■	■	■
	366-549-884	3m	0.9-1.0mm (.035-.040")	Steel Wires	■	■	■	■
	366-549-885	4.5m	0.9-1.0mm (.035-.040")	Steel Wires	■	■	■	■
	366-549-886	3m	1.2mm (.045")	Steel Wires	■	■	■	■
	366-549-887	3m	1.2mm (.045")	Steel Wires	■	■	■	■
	366-549-888	3m	1.6mm (1/16")	Steel Wires	□	□	□	□
	366-549-889	4.5m	1.6mm (1/16")	Steel Wires	□	□	□	□
Nylon	366-550-884	3m	0.9-1.0mm (.035-.040")	Soft Wires	■	■	■	■
	366-550-885	4.5m	0.9-1.0mm (.035-.040")	Soft Wires	■	■	■	■
	366-550-886	3m	1.2mm (.045")	Soft Wires	□	□	□	□
	366-550-887	4.5m	1.2mm (.045")	Soft Wires	□	□	□	□
	366-550-891	4.5m	1.6mm (1/16")	Soft Wires	□	□	□	□



Recommended Liner
 Compatible Liner

Solid Box = Recommended Liner
 Clear Box = Compatible Liner

0.6-0.9mm Wire ■ Blue

1.0-1.2mm Wire ■ Red