

## HOLEMAKER 40 ANGLE DRIVE LOW PROFILE ANGLE DRIVE DRILLING MACHINE



The Holemaker 40AD is a low profile angle drive machine providing a constant working height of 181mm. The Holemaker 40AD utilises standard 3/4" shank Holemaker cutters up to 40mm diameter and 25mm depth, ensuring a wide range of cutters is always available. The feed handle can be easily changed to either side or removed for use with a socket wrench on the hex drive, and with the combination of a 181mm constant working height, this machine can work in areas most others cannot. This machine is ideal for working with truck chassis.

The remote pressure feed coolant system, supplies cutting fluid to the centre of the annular cutter even when the machine is positioned in vertical & horizontal positions.

\*12mm twist drill capacity using Weldon Shank twist drill bits.



OPTIONAL ACCESSORIES & CONSUMABLES

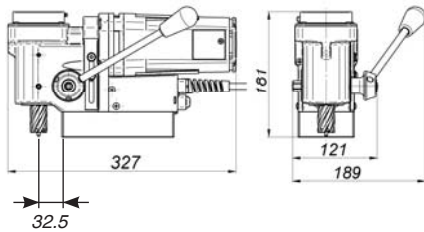

## HOLEMAKER PRO 50 #2 MORSE TAPER, DURABLE MULTI-PURPOSE MACHINE



The ability to use Holemaker cutters, No. 2 Morse Taper shank drills & reamers, as well as a drill chuck makes this a very multi-purpose machine. Satisfying most requirements with a capacity of 52mm diameter & 75mm depth of cut when using Holemaker cutters, and 23mm diameter using taper shank drills or reamers. An industrial 2 speed gearbox and 1260w motor provide a strong hardworking machine. Other standard features include cast iron construction, gravity feed coolant system & left or right hand feed handle operation. The unique semi-automatic gib adjustment system enables simple, fast and always correct fine tuning without any expert knowledge or experience.

Suitable for steel fabrication, engineering workshops & maintenance facilities where a heavy duty versatile machine is highly beneficial.

Supplied complete with arbor for use with Holemaker cutters up to 52mm depth of cut. Optional arbor to take Holemaker cutters up to 75mm depth of cut is available.

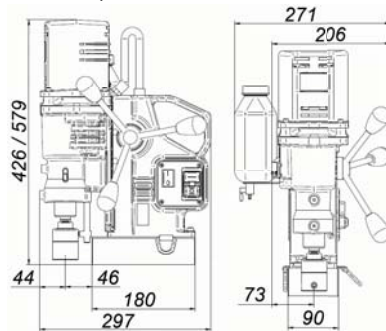

OPTIONAL ACCESSORIES & CONSUMABLES



Part No.	<b>HM40AD</b>
Capacity ( Diameter )	40mm
Capacity ( Depth )	25mm
Motor Power	1020 watt
Input Power	1100 watt Single Phase 240V
Speed	310rpm
Weight	11.1kg
Stroke	40mm
Magnetic Dead Lift	9500Nm On 25mm Steel Plate
Height ( min / max )	181mm Constant Working Height
Through Spindle Coolant System	
Smart Magnet Technology To Ensure Sufficient Magnetic Adhesion	
Supplied In Metal Carry Case With Cutter Guard & Safety Strap	

Part No.	<b>HMPRO50</b> (With Grub Screw Arbor)
Part No.	<b>HMPRO50QG</b> (With Quick Grip Arbor)
Part No.	<b>HMPRO50D</b> (With 75mm Depth Capacity)
Capacity ( Diameter )	52mm
Capacity ( Depth )	75mm
Capacity ( Twist Drill )	#2 Morse Taper 23mm
Motor Power	1260 watt
Input Power	1340 watt Single Phase 240V
Speed	2 speed 200 / 400rpm
Weight	16.5kg
Magnetic Dead Lift	12000Nm On 25mm Steel Plate
Stroke	153mm
Height ( min / max )	426mm / 579mm
Through Spindle Coolant System	
Smart Magnet Technology To Ensure Sufficient Magnetic Adhesion	
Supplied In Metal Carry Case With Cutter Guard & Safety Strap	